

Vent-A-Kiln System

Exclusive Vent-A-Kiln Features

- *Does not require kiln modification*
- *Ability to move from kiln to kiln*
- *Easy to install and maintain*
- *Models for all kiln sizes*
- *Less than one cent (1¢) per hour to operate under average conditions*
- *Available in both positive and negative pressure systems*
- *Covered with a Full 3-Year Warranty*
- *Meets applicable OSHA standards*



And here is why Vent-A-Kiln is the best venting system

- Hoods positioned directly above and close to a kiln capture the natural upward flow of hot air and fumes.
- No upsetting of a kiln's firing balance by the removal of heat from inside the kiln.
- No cold spots, within the kiln, to interfere with firing process.
- No delayed heat up time or reduction in firing temperature capability.
- No motor vibration to disturb kiln during firing since Vent-A-Kiln never comes in contact with kiln.
- Vent-A-Kiln has a proven track record of over 14 years of effective venting of unhealthy toxic fumes and unpleasant odors from thousands of kilns in schools, ceramic studios and potter shops. Many are repeat customers.

All models come as complete systems. NO extra parts to purchase

Models include aluminum hood; fan motor (115V) with 2 speed CFM control; overhead counterweight pulley system for convenience in raising hood during loading/unloading of kiln; venting kit with 10' of hose; all clamps and external mounting for outside venting.

Vent-A-Kiln Specifications

Model No.	A Hood Diameter	B Hood Depth	C Venting Diameter	Total Ship Wt.
1122	22"	4"	up to 18"	37 lb.
1227	27"	5"	19"-23"	39 lb.
1332	32"	6"	24"-28"	42 lb.
1437	37"	7 1/4"	29"-33"	44 lb.
1544	44"	7 1/4"	34"-40"	55 lb.
1654	54"	12"	41"-50"	100lb.

Models 1122 to 1437 shipped RPS or UPS
Models 1544 and 1654 shipped by truck

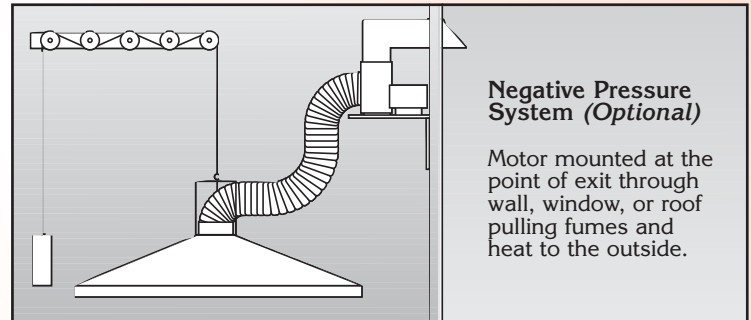
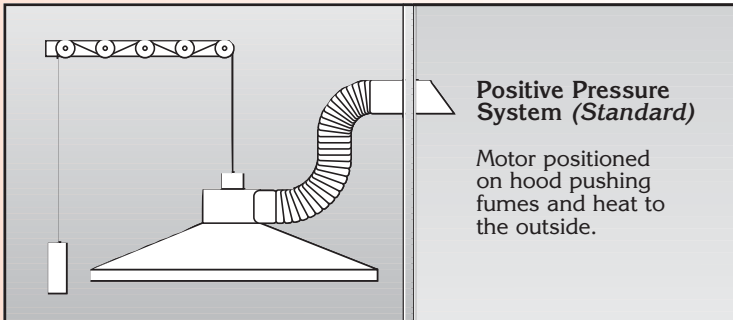
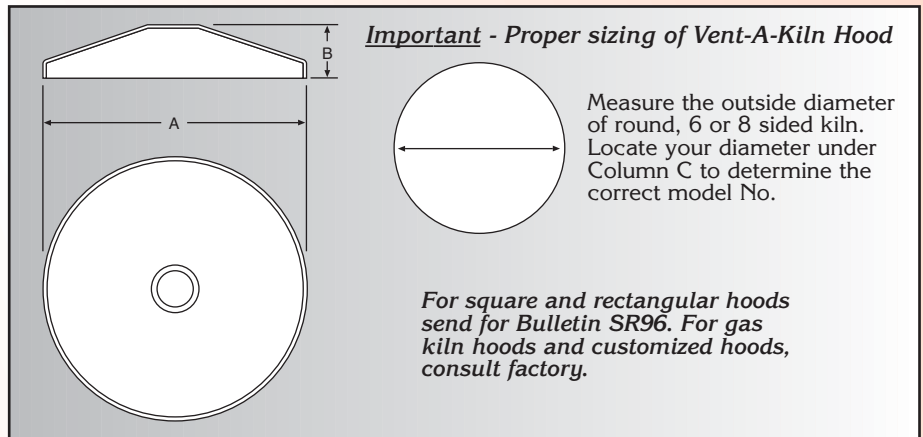

Other Kiln Safety Accessories

Mini Kiln Vent Time Controller

Automatic starting of vent prior to kiln firing eliminates the chance of forgetting to turn ventilation on. Automatic shut down of vent on a programmed time making sure all fumes have been eliminated from kiln room. Total programmable settings 84 per 7 day week 6 on 6 off per day. LCD displays real time as well as programmed time. Timer plugs into 115V receptacle and will operate any device with a maximum load of 15 Amps. 1800 watt any motor up to 1 HP. Dimension 4" x 2" x 3 1/4". Weight 5.3 oz.



Kiln Safety Screens

Free Standing • Portable • Modular • Expandable

Protection from hot kilns during firings. Screens are made with 1/2" tubular steel frames and fire resistant canvas. The standard unit consists of three hinged 2'x3' panels. Additional panels available. Each panel is imprinted in bright safety yellow. "Danger-Restricted Area" or "Caution-Kiln in Operation." Screens are also recommended for use in other hazardous areas.



VENT-A-KILN CORPORATION

621 Hertel Avenue
Buffalo, New York 14207
Phone (716) 876-2023 Fax (716) 876-4383